

**TECHNICAL DATA SHEET PHOENIX P50**



PP



PVDF+CF



ALU



AISI 316

**TECHNICAL DATA P50**

- FLUID CONNECTIONS : 1/2" BSP
- AIR CONNECTION : 1/4" BSP
- MAX FLOW RATE : 55 lt/min
- MAX AIR PRESSURE: 8 bar
- MAX DELIVERY HEAD: 80 m
- MAX SUCTION LIFT DRY: 6 m
- MAX SUCTION LIFT WET: 9,8 m
- MAX SOLID PASSING: 3,5 mm
- NOISE LEVEL: 68 dB
- DISPLACEMENT FOR CYCLE: 85 cc
- MAX VISCOSITY : 20.000 cps
- ATEX zone 2 : EX II 3/3 GD c IIB T135°C

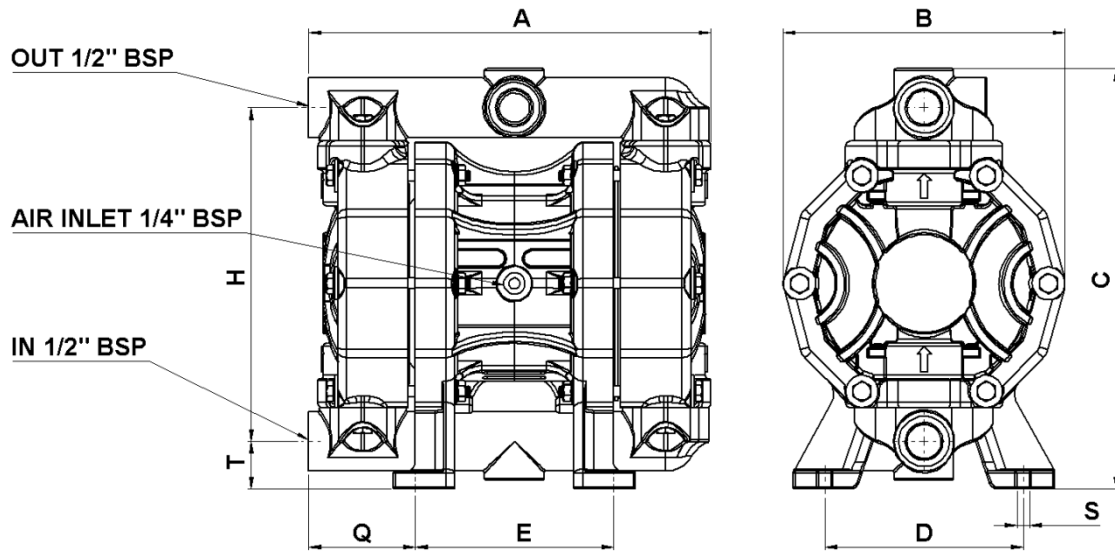
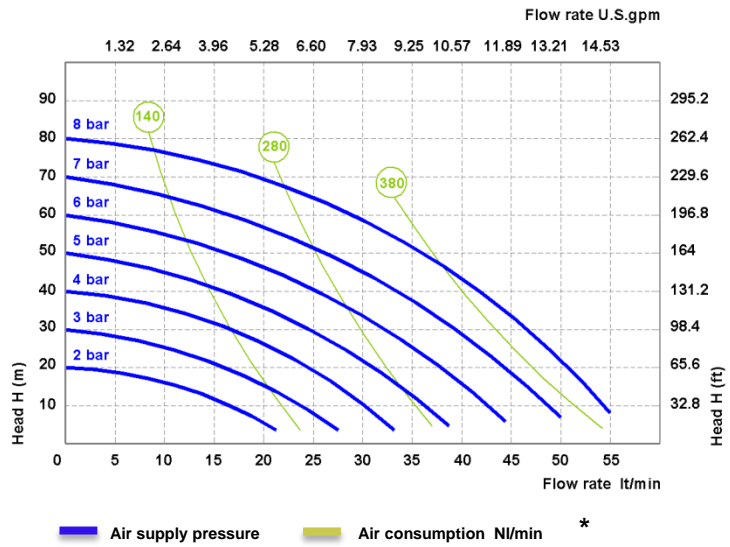

PHOENIX P50	A	B	C	D	E	H	Q	S	T	Weight Kg	Max Temperature
PP	222	153	233	110	110	185	59	7	27	4	65 °C
PVDF+CF	222	153	233	110	110	185	59	7	27	4,5	95 °C
ALU	225	156	230	110	110	183	59	7	26	5	95 °C
AISI 316	225	156	230	110	110	183	59	7	26	6	95 °C

\* The curves and performance values refer to pumps with submerged suction and a free delivery outlet with water at 20°C, and vary according to the construction material. Technical data are approximate and not binding for the manufacturer who reserves the right to change them without notice at any time.

**COMPOSITION**

MODEL	CASING	DIAPHRAGM	BALL	SEATS	GASKET	CONNECTIONS	ATEX	PORTS IN/OUT
P0050	P= PP KC= PVDF+CF A= ALU S=SS	HT=HYTREL+PTFE MT=SANTOPRENE+PTFE H=HYTREL N=NBR	T= PTFE S= SS D=EPDM N=NBR	P=PP K=PVDF A=ALU S=SS Z=PE-UHMWE	D=EPDM V=VITON N=NBR T=PTFE	1=BSP 2=FLANGED 5=NPT	- = zone 2	AB=Standard

**AVAILABLE CONNECTIONS**

Standard = A B  
IN = A-E-T-C-G  
OUT =B-S-D-F-P

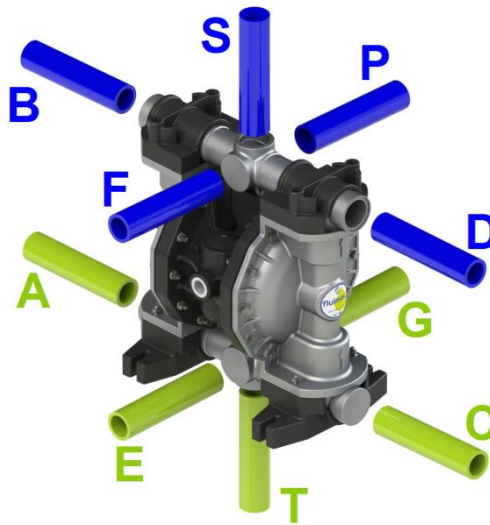

**HOW TO READ THE CODE**

